

CAD FILE:

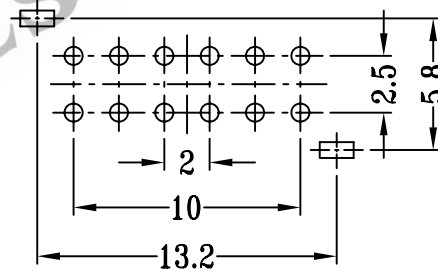
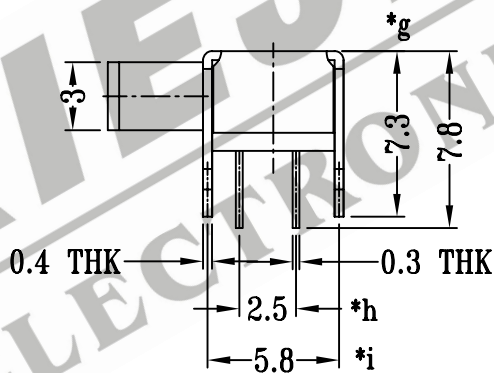
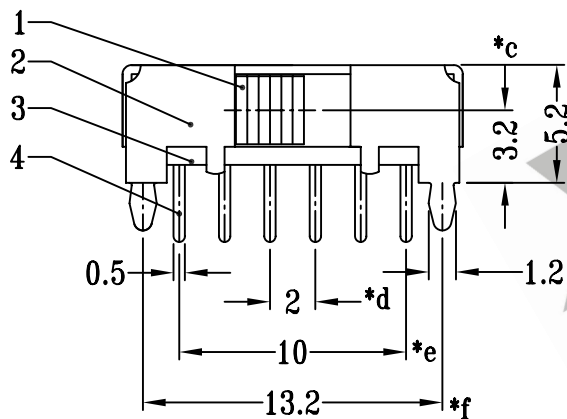
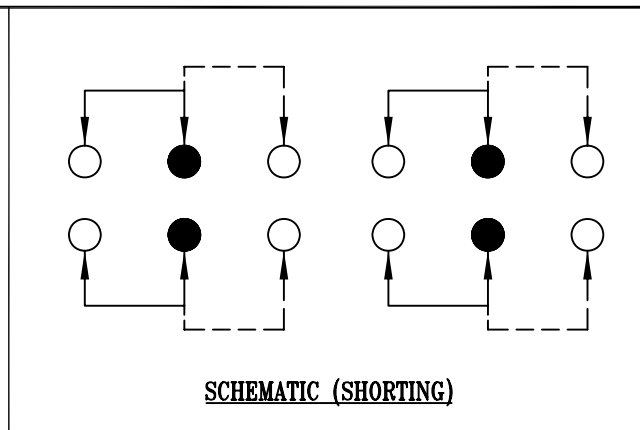
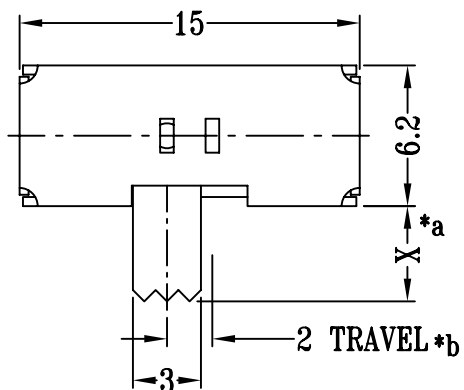

P.C.B LAYOUT

注：“\*”表示关键尺寸（8个）

8					TOLERANCE	SHENZHEN XIEJIA ELECTRONICS CO.,LTD.				
7					UNLESS SPECIFIED					
6	SPRING PLATE	STAINLESS STEEL	1	NATURAL	WITHIN: 1.5±0.1mm	ISSUE	DATE	DESCRIPTIONS OF REVISION		APPD.
5	CONTACT CLIP	PBS	4	Ag CLAD	OVER: 1.5±0.2mm					
4	TERMINAL	BRASS STRIP	12	Ag PLATED OVER Ni PLATED	TITLE : HORIZONTAL SLIDE SWITCH	UNIT : mm		DRWG NO.: XJ-DR-SK42D01-00		
3	BASE	PHENOLIC RESIN	1	NATURAL	MODEL: SK-42D01	SCALE: 3:1		DWN.	ZHOUYU	2007-5-3
2	FRAME	STEEL STRIP	1	Ni PLATED				CHK'D	FANGYING	2007-5-3
1	KNOB	POM	1	BLACK	ALL MATERIALS MUST BE COMPLIANT TO ROHS			APPD.	KANGXINAN	2007-5-3
NO.	PARTS	MATERIALS	Q'TY	FINISH						